

EUROMACH



Management System
ISO 9001:2008



www.tuv.com
ID 9105027671

R 853

EUROMACH

Creata nel 1977, la Euromach Srl garantisce ai clienti (50% dei quali all'estero) 40 anni di esperienza nella costruzione di escavatori ragno (oltre 2500 in tutto il mondo) destinati non solamente alle aree montane, ma anche a quelle paludose e ai canali. L'azienda è certificata ISO 9001 e collabora con i principali produttori mondiali di componenti tecnologici per il miglioramento costante e la ricerca continua di nuove soluzioni per accrescere l'efficienza e la sicurezza delle macchine, alla base del successo dell'azienda. Gli escavatori "ragno" Euromach si distinguono per la loro capacità di lavorare in terreni molto ripidi e difficili, dove l'accesso ai normali mezzi è proibito.

Set up in 1977, Euromach S.r.l grants to their customer (50% of which in foreign countries) 40 years of experience in the construction of walking excavators (more than 2500 all around the world), that are destined to work not only in mountain areas, but also in swamps and channels. The company obtained also the certification ISO 9001 and cooperates with the main world producers of technological components for constant improvement and machines' security, which are the reasons behind the company success. Euromach excavators are ideally suited to work on very steep or rough-terrain sites, where access is severely restricted.

Crée en 1977, Euromach Srl garantie aux clients (dont 50% à l'étranger) 40 années d'expérience dans la construction des pelles araignées (plus de 2500 dans le monde entier) aux terrains de montagne, mais aussi terrains marécageux et aux cours d'eau. L'entreprise est certifiée ISO 9001 et collabore avec les principaux producteurs mondiales de composants technologiques pour une amélioration constante et une recherche continue des nouvelles solutions dans le but d'augmenter l'efficacité et la sécurité des machines, qui sont à la base du succès de l'entreprise. Les pelles araignées Euromach se distinguent pour leur capacité à travailler dans des terrains très raides et difficiles, où l'accès aux moyens traditionnels est interdit.

Die Firma Euromach Srl, wurde im Jahr 1977 gegründet und bringt somit ihren Kunden, welche sich zu 50% im Ausland (mehr als 2500 in der Welt) befindet, eine Erfahrung von über 40 Jahren in der Herstellung von Schreitbaggern entgegen und bürgt daher für technologisch innovative Produkte. Diese Schreitbagger sind für Einsätze konstruiert, welche für andere Maschinen nicht oder nur schwer durchführbar sind. Diese Einsätze beschränken sich nicht nur auf Bergland, Euromach Schreitbagger eignen sich auch besonders gut für Einsätze in sumpfigen Gebieten und Kanälen. Die ISO 9001 Zertifikat gewährleistet die Verwendung von technologischen Komponenten marktführender namhafter Hersteller und eine stetige Forschung und Weiterentwicklung um die Leistung, Standhaftigkeit und Sicherheit der Maschinen zu erhöhen, was nicht zuletzt den Erfolg der Firma begründet.



TIGROTTO



1300 SUPER JOLLY



3500 MOBILE



5500 MOBILE



6500 MOBILE



8500 MOBILE

R 853



Il nuovo escavatore Euromach R853 monta un motore Kubota da 115 HP omologato Stage IIIB con filtro antiparticolato incluso; una nuova cabina con migliore visibilità, ergonomia, design e nuovi cofani che ne migliorano l'estetica. L'impianto idraulico per la traslazione ha una pompa idrostatica Rexroth e il distributore del braccio è di tipo Load Sensing. L'impianto idraulico è composto da n. 5 pompe.

The new excavator Euromach R853 mount a 115 HP Kubota engine homologated Stage IIIB with the particulate filter included; a new cab with better visibility, ergonomic, design and new bonnets that improve the aesthetic of the machine. The hydraulic system for the motion has a Rexroth hydrostatic pump and the controlling valve of the boom is in Load Sensing. The hydraulic system is composed by n. 5 pumps.

La nouvelle pelle Euromach R853 monte un moteur Kubota de 115HP homologué Stage IIIB avec le filtre à particules inclus; une nouvelle cabine avec meilleure visibilité, ergonomie et design et nouveaux capots qui en améliorent l'esthétique. Le système hydraulique pour la translation a une pompe hydrostatique Rexroth et le distributeur du bras est de type Load Sensing. Le système hydraulique est composé par n. 5 pompes.

Beim neuen Schreitbagger Euromach R853 wird der neue Motortyp Kubota mit 115HP, integriertem Partikel-filter und homologierter Stage IIIB montiert; eine neue Kabine mit verbesserter Sicherheit, Ergonomie und Design und neuer Motorhaube für eine bessere Ästhetik. Die Antriebshydraulikanlage hat eine Rexroth hydrostatische Pumpe und der Verteiler des Armes ist vom Typ Load Sensing. Die gesamte Hydraulikanlage hat 5 Pumpen.

Escavatori Euromach / Euromach excavators Pelles Euromach / Bagger Euromach

1500 MOBILE



2500 MOBILE



R45



R55



R 55 100 HP



R65 Super Power



R653



R105



R1253



R145





EUROMAGH







Braccio / Boom / Bras / Arm



4 diverse configurazioni braccio: sbraccio massimo da 7750 mm (A) a 8450 mm (D).

4 different configurations of the boom: maximum boom length from 7750 mm (A) to 8450 mm (D).

4 configurations différentes du bras: longueur maximum du bras de 7750 mm (A) à 8450 mm (D).

4 verschiedene Anfertigungen des Armes: Höchst-rechtweite von 7750 mm (A) bis 8450 mm (D).



N. 5 tubi di serie in punta al braccio. In opzione personalizzabile fino a n. 13 tubi.

N. 5 standard tubes at the end of the boom. In option customizable until to n. 13 tubes.

Num. 5 tuyaux de série à la fin du bras. En option personnalisable jusqu'à n. 13 tuyaux.

Nr. 5 serienmäßige Ölleitungen am Ende des Armes. Optional anpassbar bis zu n. 13 Ölleitungen.



Valvole di sicurezza su bracci.

Security valves on the booms.

Clapets de sécurité sur les bras.

Ventilenkit über die Zylindern.



Tutti i tubi a sinistra in posizione visibile.

All the pipes on the left in visible position.

Touts les tuyaux à la gauche en position visible.

Alle Leitungen an der linken Seite in einer gut sichtbaren Position.



Bielle e puntone derivati da un ragno di 14 ton.

Balance rod and strut rod derived from a spider of 14 ton.

Bielletes et punton derivés d'une araignée de 14 ton.

Pleuel und Löffelstange von 14 ton Schreitbagger übernommen.



Telaio / Chassis / Châssis / Chassis



option



option



Zampe / Legs /



Pattes / Bügeln



Ruote anteriori con fusello maggiorato.

Front wheels with increased spindle.

Roues avant avec moyeau majoré.

Vorer Raden mit verstärkten Achsschenkeln.



Riduttori maggiorati con motore a cilindrata variabile.

Increased gearmotors with variable displacement engines.

Réducteurs à puissance supérieure avec moteurs à débit variable.

Potenzierte Hydromotoren mit variabler Leistung.



Blocco del differenziale.

Lockig system device.

Blocage du différentiel.

Sperrdifferential.



Stili zampe indipendenti.

Independent telescopic legs.

Extensions des pattes indépendantes.

Unabhängige Teleskopbeine.



option

Nokian



option

Michelin



option

Staffe sterzanti.

Steering legs.

Pattes avec direction.

Lenkräder.

Nuova cabina / New cab / N



ouvelle cabine / Neue Kabine

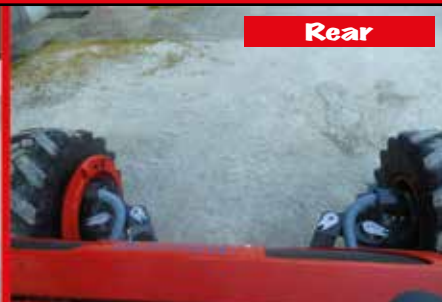

Optionals



Climate system Grammer



Right headlight



Lexan



Motore / Engine / Moteur / Motor

PERFORMANCE CURVE

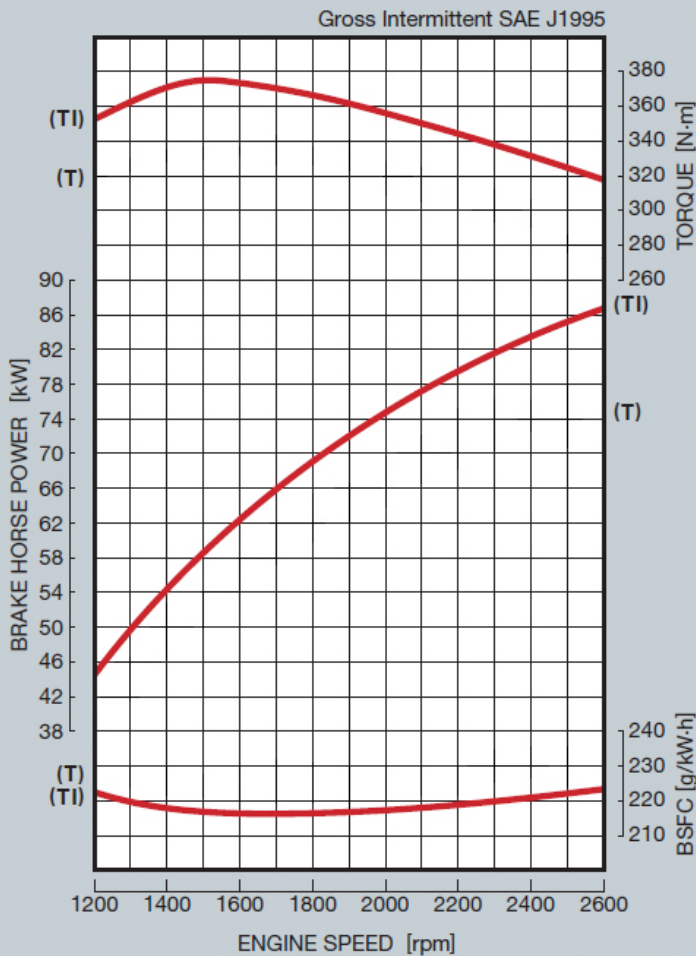

TIER III B

Kubota



Modello: Kubota V3800 Stage III B con filtro antiparticolato
Tipo: Diesel Turbo 4 tempi raffreddato ad acqua, Intercooler
Numero cilindri: 4
Cilindrata: 3769 cm³
Potenza massima: 115 Hp (85 kW)
Tensione alimentazione: 12 V
Alternatore: 100 A/h

Model: Kubota V3800 Stage III B with particulate filter
Type: 4 strokes water-cooled turbo Diesel, Intercooler
Cylinders number: 4
Displacement: 3769 cm³
Max power: 115 Hp (85 kW)
Electric system: 12 V
Generator: 100 A/h

Modèle: V3800 Stage III B avec filtre à particules
Type: Turbo Diesel 4 temps refroidissement par liquide, Intercooler
Nombre des cylindres: 4
Cylindrée: 3769 cm³
Puissance maximum: 115 Hp (85 kW)
Tension du moteur: 12 V
Générateur: 100 A/h

Modell: V3800 Stage III B mit Partikelfilter
Typ: Viertakt- Turbodieselmotor mit Flüssigkeitskühlung, Intercooler
Zylinderanzahl: 4
Hubraum: 3769 cm³
Höchstleistung: 115 Hp (85 kW)
Speisespannung: 12 V
Wechselstromgenerator: 100 A/h

Nuove sensibilità e affidabilità New sensibility and reliability

Valvola Rexroth di nuova concezione sul cilindro di sollevamento (più sensibile).

Nuova valvola Rexroth rigenerativa sul cilindro del secondo braccio.

Rexroth valve of new concept on the lifting boom (more sensibility).

New regenerative Rexroth valve on the second boom cylinder.



Valve Rexroth de nouvelle conception sur le vérin du levage (plus sensible).

Nouvelle valve régénératrice Rexroth sur le vérin du deuxième bras.

Rexroth Ventil von neuer Konzeption auf dem Hubzylinder (mehr Sensibilität).

Neues regeneratives Rexroth Ventil auf dem Zylinder des zweites Armes.

Rex
Bosch

La nuova valvola Rexroth di rotazione ha il corpo in acciaio ed una selezione di due modalità (dolce / aggressivo).

La nouvelle valve de rotation Rexroth a un corps en acier et une sélection de deux modalités (douce / agressive).

New motion control valve for the swing has a steel housing and a selection of two modes (sweet / aggressive).

Das neue aus Stahl hergestellte Drehbremsventil hat eine Auswahl von zwei Modus (weich / aggressive).



Nouvelle sensibilité et fiabilité Neue Sensibilität und Zuverlässigkeit



Una nuova valvola Rexroth sul traino funge da blocco del differenziale. Le 2 ruote si muoveranno in modo sincrono anche con differenti pressioni al suolo delle stesse.

A new Rexroth valve on the traction makes the differential locking device function. The 2 wheels will move synchronously even if they have different pressures to the ground.

Une nouvelle valve Rexroth sur la traction fait le blocage du différentiel. Les 2 roues se déplacent en manière synchrone même s'elles ont des pressions différentes sur le sol.

Ein neues Ventil Rexroth auf den Antrieb macht die Funktion als Sperrdifferential. Beide Räder werden in einer synchronen Weise, sogar mit unterschiedlichen Drücken auf den Boden bewegt.

roth
Group



Abbiamo sviluppato con Hydreco dei nuovi corpi manipolatori. Lo sforzo per comandare la leva è molto basso e la sensibilità sul movimento del cilindro molto maggiore.

In cooperation with Hydreco we have developed new bodies for the manipulators. The effort to control the lever is very low and the sensitivity on the cylinder movement is higher.

Nous avons développé avec Hydreco de nouveaux corps de manipulateurs. L'effort pour contrôler le levier est très bas et la sensibilité sur le mouvement du vérin est supérieure.

Wir haben mit Hydreco neue Körper für die Manipulatoren entwickelt. Der Aufwand um den Hebel zu kontrollieren ist sehr niedrig und die Sensibilität der Zylinderbewegung ist viel größer.

HYDRECO
HYDRAULIC SOLUTIONS PROVIDER

Impianto principale - Braccio

Main system - Boom

Système principal - Bras

Hauptanlage - Arm



Rexroth

Bosch Group



N. 5 pompe

N. 3 distributori separati

Totale olio: 110 + 110 + 112 + 32 + 22 = 386 l/min

Pressione di lavoro: 300 bar

N. 5 pumps

N. 3 separated control valves

Total oil: 110 + 110 + 112 + 32 + 22 = 386 l/min

Working pressure: 300 bar

N. 5 pompes

N. 3 distributeurs séparés

Totale huile: 110 + 110 + 112 + 32 + 22 = 386 l/min

Pression de travail: 300 bar

N. 5 Pumpen

N. 3 getrennte Verteiler

Gesamtöl: 110 + 110 + 112 + 32 + 22 = 386 l/min

Arbeitsdruck: 300 bar

Impianto di traslazione mediante pompa idrostatica e motori Rexroth a cilindrata variabile.

**Pressione di lavoro 450 bar
Portata massima 112 L/min
Velocità massima 8 Km/h
(option 12 km/h).
Grande potenza.**

Translation system with hydrostatic Rexroth pump and variable displacement engines.

**Working pressure 450 bar
Max. displacement 112 L/min
Max. speed 8 Km/h (option 12 km/h).**

Système de translation avec pompe hydrostatique et moteurs Rexroth à débit variable.

**Pression de travail 450 bar
Débit maximum 112 L/min
Vitesse maximum 8 Km/h
(option 12 km/h).
Grande puissance.**

Fahrtriebepumpe vom Typ „Rexroth“ hydrostatisch und Motor mit variabler Leistung.

**Arbeitsdruck 450 bar
Max. Leistung 112 L/min
Höchstgeschwindigkeit 8 Km/h
(Option 12 km/h).
Große Macht.**

Impianto di traslazione Translation system Système de translation Fahrtriebepumpe



Rexroth

Bosch Group



OPTION: Priority Line



Linea prioritaria per accessorio idraulico con portata e pressione indipendenti dal movimento dell'escavatore.

Priority line for the hydraulic accessory with independent displacement and pressure from the excavator movement.

Ligne prioritaire pour accessoire hydraulique avec débit et pression indépendants du mouvement de la pelle.

Vorrangige Linie für Hydraulikzubehör mit Leistung und Druck unabhängig von der Bewegung des Baggers.

R 853

DATI PRINCIPALI

- ⇒ N° 2 serbatoi del gasolio = 290 lit (principale 130 lit, secondario nel telaio 160 lit). L'escavatore è munito di una pompa per il trasferimento del carburante dal serbatoio secondario a quello principale.
- ⇒ Cabina antiribaltamento, nuovo disegno, con vetro apribile verso l'interno, ROPS/FOPS, miglior confort e più spazio per l'operatore; cristalli temperati, autoradio con CD e sedile ad aria.
- ⇒ I componenti maggiormente sollecitati sono realizzati utilizzando materiali ad alto limite elastico. I cucchiai ed i piedi di appoggio sono con particolari acciai antiusura per aumentarne la resistenza all'uso. I perni sono realizzati in acciaio 16CrNi4 cementato e gli steli dei cilindri sono in 42CrMo4 bonificato e temprato ad induzione e successivamente cromato per avere massima robustezza e resistenza all'usura.

DONNES PRINCIPALES

- ⇒ N° 2 réservoirs à gasoil = 290 lit (principale 130 lit, réserve 160 lit). La pelle est équipée d'une pompe qui peut être utilisé pour le transfert du carburant du réservoir secondaire à ce principal.
- ⇒ Cabine anti-renversement, nouvel design, vitre antérieure avec ouverture à l'intérieur, ROPS/FOPS, plus de confort, plus d'espace pour l'opérateur, glaces trempées et colorées, autoradio avec CD, siège à air.
- ⇒ Les parties de l'excavateur les plus fatiguées, sont réalisées avec de matériels qui ont une limite d'élasticité très élevée. Les bennes et les pieds d'appui sont réalisés en acier spécial avec une résistance élevée à l'usure. Les pivots sont réalisés en acier 16CrNi4 cémenté et les tiges des cylindres sont réalisés en acier 42CrMo4 bonifié et trempé à induction et successivement chromé afin de garantir une considérable robustesse et une résistance de la surfaces aux chocs très élevés.

MAIN DATA

- ⇒ N° 2 diesel tanks = 290 lit (main tank 130 lit, secondary tank 160 lit). The excavator is equipped with a pump that can be used to transfer the Diesel form the secondary tank to the main tank.
- ⇒ Anti-roll cabin, new design, front window opens towards the cabin, ROPS/FOPS, more comfort, more space for the operator, tempered and colored glass windows, car radio set with CDs, air seat.
- ⇒ The most stressed parts of the excavator are made out of high strength steel. Buckets and legs are made out of special steel that has a high resistance against wearing. The pins are made out of case-hardened 16CrNi4 steel and the cylinders piston rods are made out off induction hardened and tempered 42CrMo4 steel successively chromed to warrant a good strength and a surface resistance against chocks.

HAUPTDATEN

- ⇒ N° 2 Treibstofftanks = 290 Lit. (Haupttank 130 Lit, Ersatztank 160 Lit). Eine spezifische Tankpumpe wird geliefert, um den Treibstoff vom Ersatztank in den Haupttank zu pumpen.
- ⇒ Kippsichere Kabine, neues Design, Vorderscheibe mit Öffnung nach Innen, ROPS/FOPS, besseren Komfort, mehr Platzangebot für der Maschinenführer, gehärtete Scheiben, Autoradio mit CD, LuftsitzKab.
- ⇒ Die Komponente des Baggers, welche Höchstbeanspruchung haben, werden aus hohem elastischem Qualitätsmaterial hergestellt. Die Löffeln und die Auflagefüße werden aus besonderen Antiverschleißstählen gemacht, um die Gebrauchsfestigkeit zu erhöhen. Die Bolzen werden aus Stahl 16CrNi4 hergestellt und die Kolbenstangen werden aus vergütetem, induktionsgehärtetem und danach verchromten 42CrMo4 Stahl hergestellt; das verbürgt für eine bemerkenswerte Stärke und eine hohe oberflächliche Schlagfestigkeit.

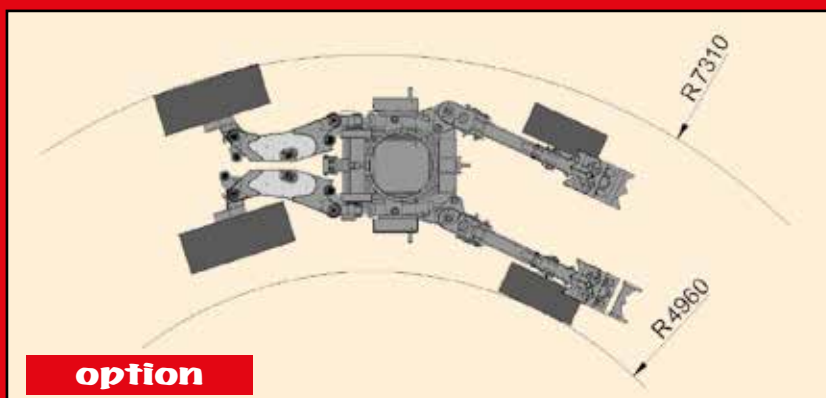
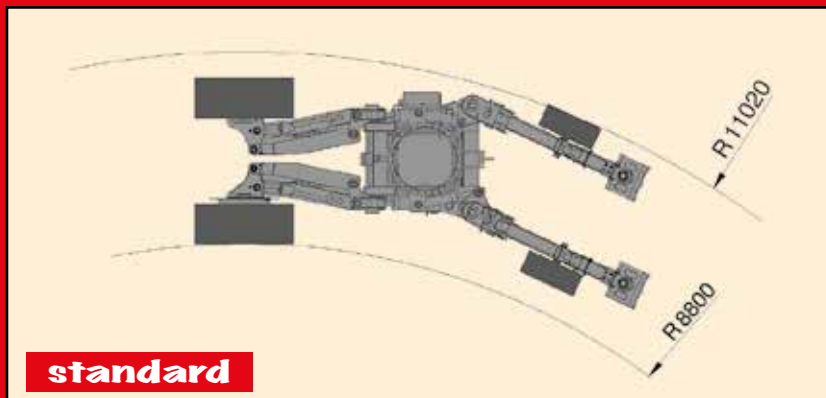

4wd wheels tilting system (option)

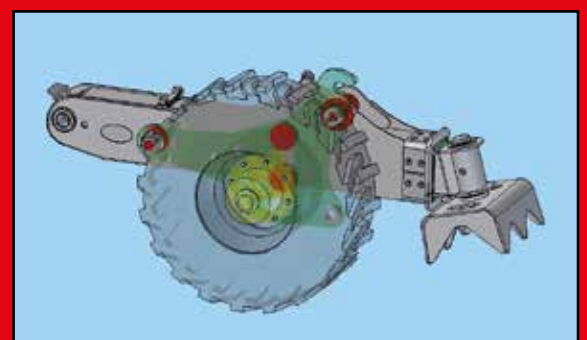
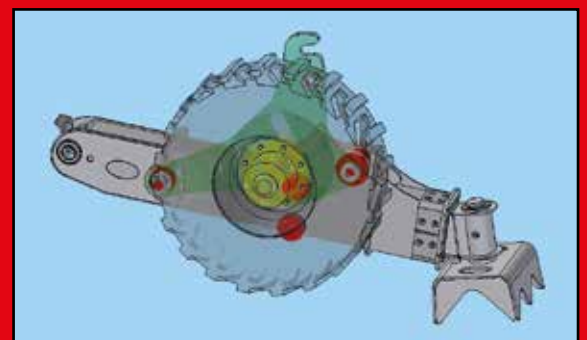

Standard version

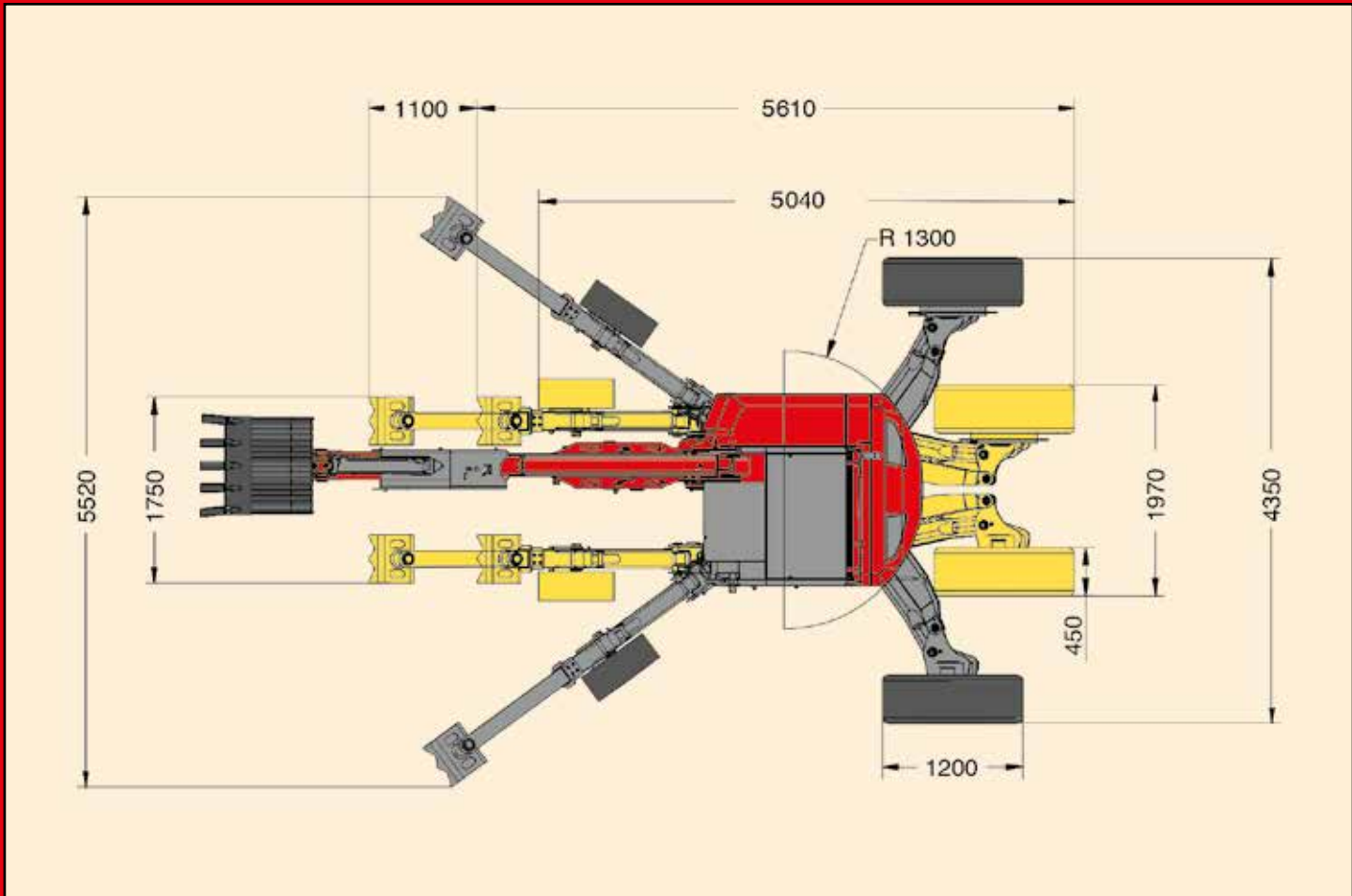

Steering legs (option)

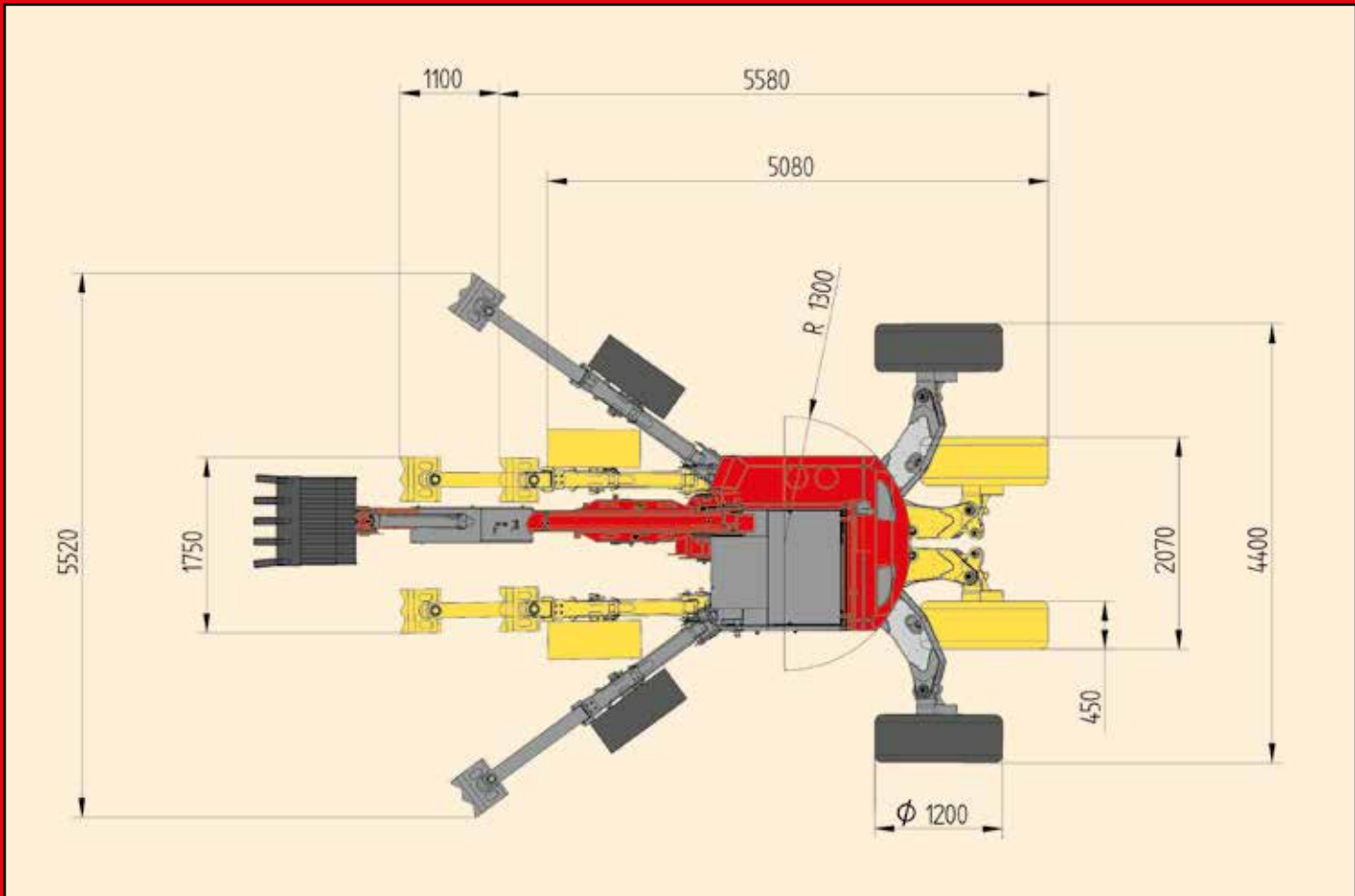

R 853 - Version A

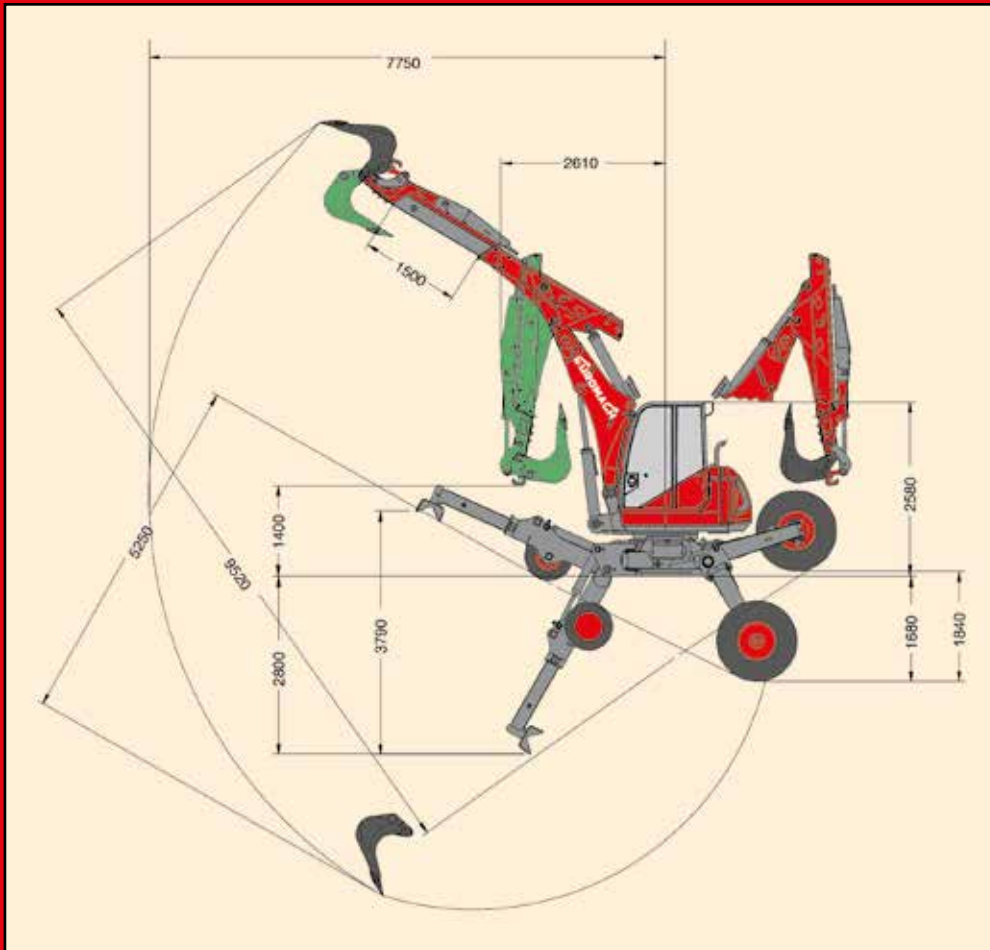

Peso 2wd: da 9000 kg
Peso 4wd: da 9500 kg
Sfilo braccio: 1,5 m
Sbraccio massimo: 7,75 m
Forza di strappo: 110 kn
Forza di penetrazione: 62 kn

Weight 2wd: from 9000 kg
Weight 4wd: from 9500 kg
Boom extension: 1,5 m
Max. boom length: 7,75 m
Brake off force: 110 kn
Penetration force: 62 kn

Poids 2wd: de 9000 kg
Poids 4wd: de 9500 kg
Extension du bras: 1,5 m
Longueur max. bras: 7,75 m
Force d'enlèvement: 110 kn
Force de pénétration: 62 kn

Gewicht 2wd: von 9000 kg
Gewicht 4wd: von 9500 kg
Teleskop Ausleger: 1,5 m
Höchststreckweite: 7,75 m
Reißkraft: 110 kn
Durchschlagskraft: 62 kn

R 853 - Version B

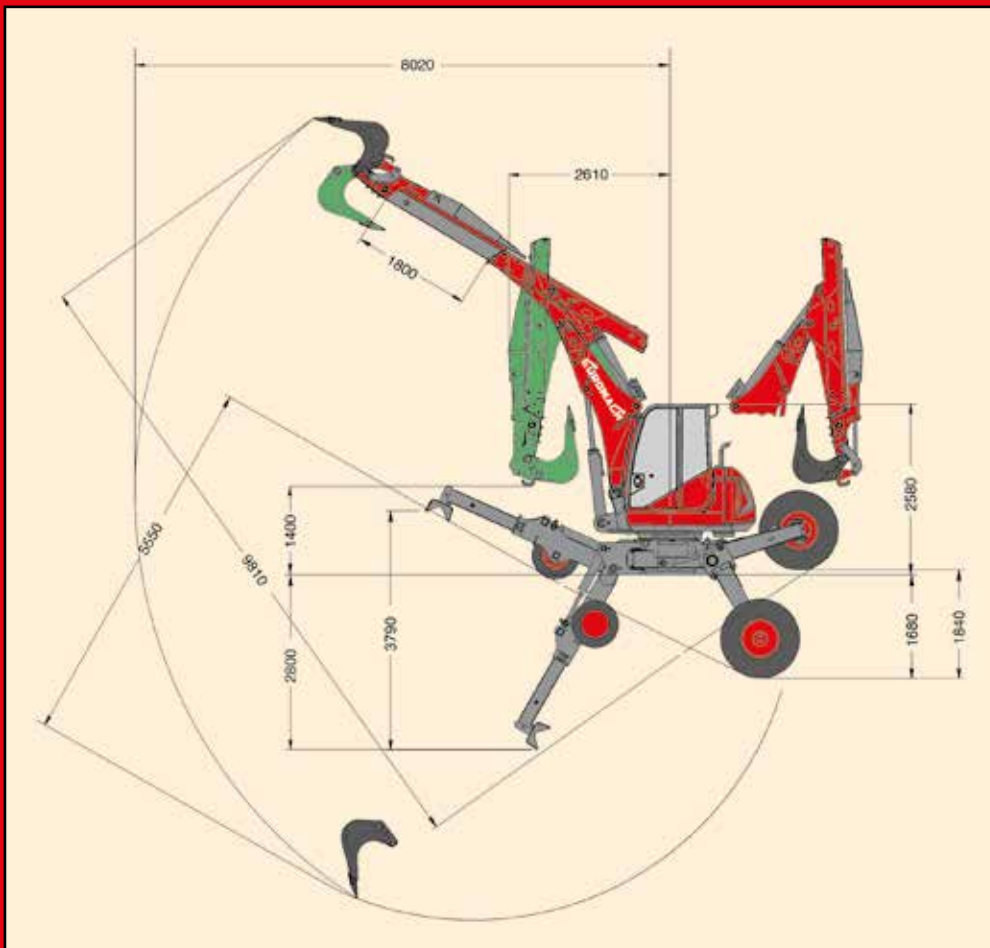

Peso 2wd: da 9100 kg
Peso 4wd: da 9600 kg
Sfilo braccio: 1,8 m
Sbraccio massimo: 8,02 m
Forza di strappo: 110 kn
Forza di penetrazione: 62 kn

Weight 2wd: from 9100 kg
Weight 4wd: from 9600 kg
Boom extension: 1,8 m
Max. boom length: 8,02 m
Brake off force: 110 kn
Penetration force: 62 kn

Poids 2wd: de 9100 kg
Poids 4wd: de 9600 kg
Extension du bras: 1,8 m
Longueur max. bras: 8,02 m
Force d'enlèvement: 110 kn
Force de pénétration: 62 kn

Gewicht 2wd: von 9100 kg
Gewicht 4wd: von 9600 kg
Teleskop Ausleger: 1,8 m
Höchststreckweite: 8,02 m
Reißkraft: 110 kn
Durchschlagskraft: 62 kn

R 853 - Version C

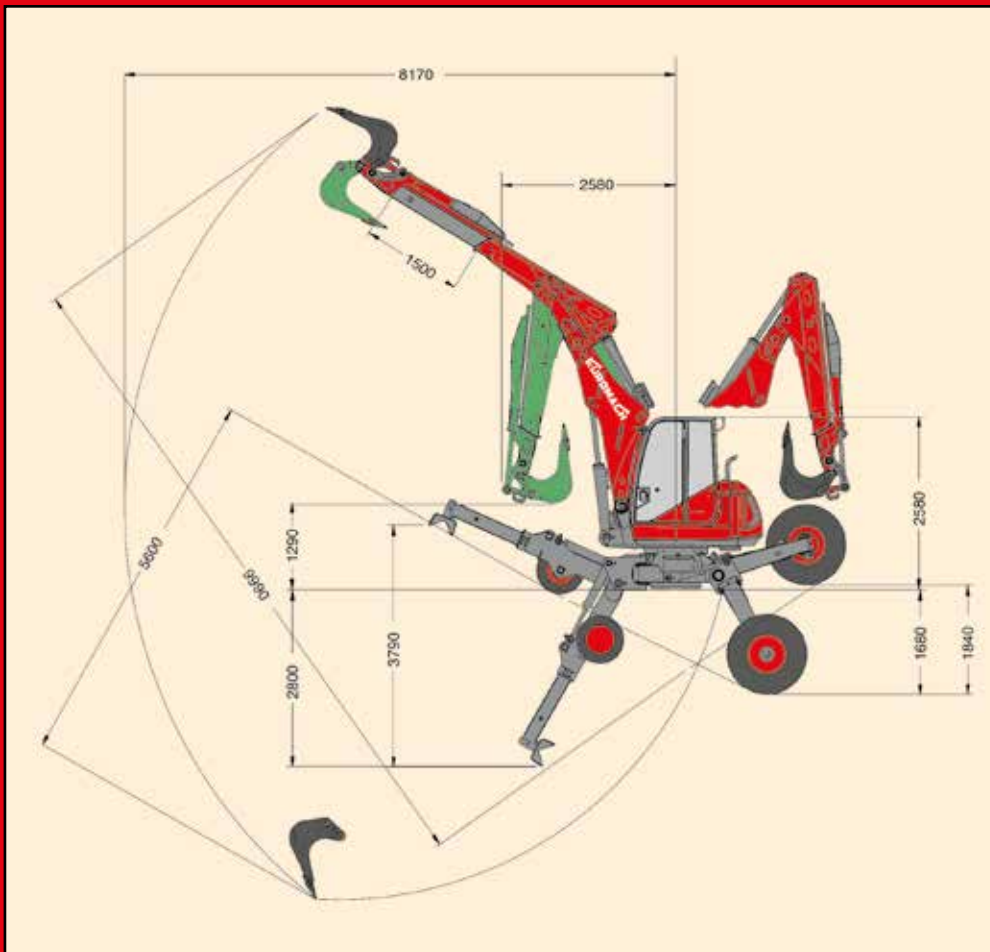

Peso 2wd: da 9200 kg
Peso 4wd: da 9700 kg
Sfilo braccio: 1,5 m
Sbraccio massimo: 8,17 m
Forza di strappo: 110 kn
Forza di penetrazione: 65 kn

Weight 2wd: from 9200 kg
Weight 4wd: from 9700 kg
Boom extension: 1,5 m
Max. boom length: 8,17 m
Brake off force: 110 kn
Penetration force: 65 kn

Poids 2wd: de 9200 kg
Poids 4wd: de 9700 kg
Extension du bras: 1,5 m
Longueur max. bras: 8,17 m
Force d'enlèvement: 110 kn
Force de pénétration: 65 kn

Gewicht 2wd: von 9200 kg
Gewicht 4wd: von 9700 kg
Teleskop Ausleger: 1,5 m
Höchststreckweite: 8,17 m
Reißkraft: 110 kn
Durchschlagskraft: 65 kn

R 853 - Version D

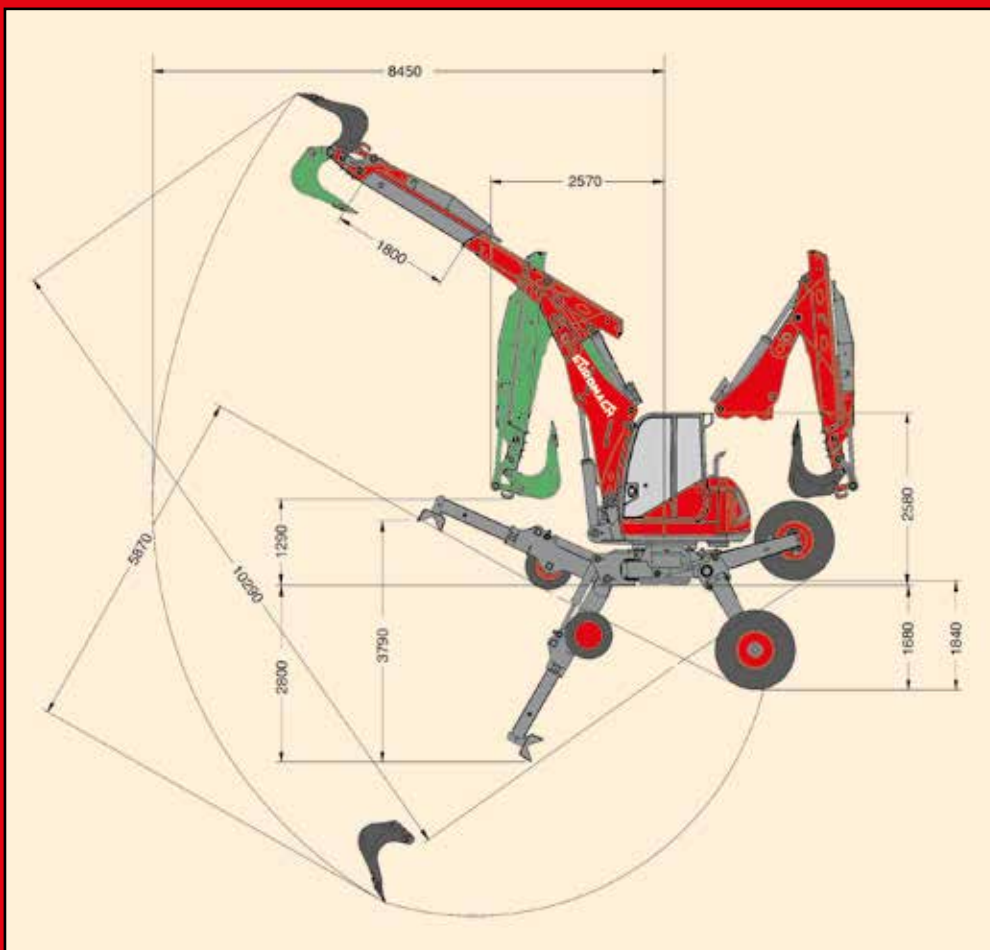

Peso 2wd: da 9300 kg
Peso 4wd: da 9800 kg
Sfilo braccio: 1,8 m
Sbraccio massimo: 8,45 m
Forza di strappo: 110 kn
Forza di penetrazione: 65 kn

Weight 2wd: from 9300 kg
Weight 4wd: from 9800 kg
Boom extension: 1,8 m
Max. boom length: 8,45 m
Brake off force: 110 kn
Penetration force: 65 kn

Poids 2wd: de 9300 kg
Poids 4wd: de 9800 kg
Extension du bras: 1,8 m
Longueur max. bras: 8,45 m
Force d'enlèvement: 110 kn
Force de pénétration: 65 kn

Gewicht 2wd: von 9300 kg
Gewicht 4wd: von 9800 kg
Teleskop Ausleger: 1,8 m
Höchststreckweite: 8,45 m
Reißkraft: 110 kn
Durchschlagskraft: 65 kn

Accessori / Accessories

CUCCHIAI / BUCKETS / BENNES / LÖFFELN



ARGANI / WINCHES / TREUILS / WINDEN



PINZE / GRABS / BENNES PRENEUSES / GREIFERN



Accessoires / Zubehöre

FRESE E PROCESSORI / MULCHERS AND PROCESSORS BROYEURS ET PROCESSEURS / MULCHERN UND PROZESSOREN



ROTATORI E ATTACCHI RAPIDI / ROTATORS AND QUICK COUPLERS ROTATEURS ET ATTACHES RAPIDES / ROTATOREN UND SCHNELLWECHSLERN



ALTRI ACCESSORI / OTHER ATTACHMENTS AUTRES EQUIPEMENTS / ANDERE ZUBEHÖRE





R 853

EUROMACH S.R.L.
25018 MONTICHIARI (Brescia)
ITALY
Via Gabriele D'Annunzio, 28/30
Phone 0039(0)-30-9960527
Fax 0039(0)-30-9960363
www.euromach.com
e-mail: euromach@euromach.com



- A fronte di una continua ricerca tecnologica, i dati possono cambiare senza preavviso. Contattare il nostro Ufficio Commerciale per ulteriori informazioni.
- Because of continuous technology research data can change without notice. Please, contact our Commercial Dept. for further information.
- Vu la recherche technologique continue, les données peuvent changer sans préavis. Contacter notre Bureau Commercial pour des autres informations.
- Wegen technischer Forschung, können die Daten fristlos ändern. Unser Vertrieb erteilt Ihnen gerne weitere Auskünfte, bitte rufen Sie an.

Ed 01/16 - Rev 0